

2025/1/9



CH700UV

BROCHURE



INTRODUCE

CH700UV High-resolution Inkjet Printing System can not only print text, serial numbers, production dates, logos, and pictures, but also variable bar codes, QR codes, and other contents. The printed font patterns are clear and beautiful, with uniform color, the resolution can reach up to 360 DPI, and the ink adhesion is good. The unique ink circuit design ensures continuous and stable high-speed operation 7*24 hours a day.

Equipped with CYCJET's multiple patented innovative intelligent negative pressure ink supply system to ensure that the equipment operates at high-speed stable operation, no deinking, continuous line, and no ink accumulation. Advanced technologies such as multi-level constant temperature, fault warning, multi-level liquid level management, one-click emptying, and one click machine cleaning are all applied. The splicing of multiple nozzles can achieve a maximum printing height of 287.2mm, which is widely used in logistics packaging, building materials, film rolls, electronics, gas transportation, cables, pipes, hardware, food, beverages, medicine chemicals and other industries.

CH700UV

Excellent design, portable size and appearance

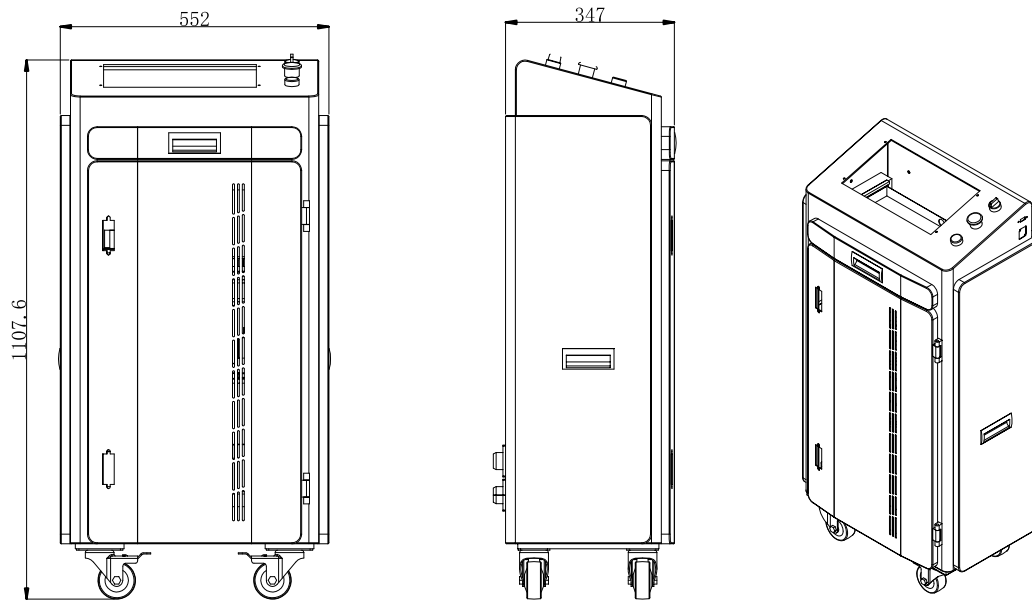

The compact and small design makes it easy to apply to any production line. The aluminum alloy shell can fully protect the machine from damage. The large touch screen design and the internal intelligent system make it easy to edit and print content.



The print head is high-resolution that can reach 360DPI. It has large printing format, a single nozzle can reach 71.8mm, and the maximum printing speed can reach 90m/min. It supports printing text, numbers, patterns, QR codes, bar codes, etc.



It can realize multi-head splicing to achieve larger-format printing effects, and can also be controlled by software, making it convenient for users to operate and maintain.



The machine can be linked with other equipment on the production line to achieve automated production. It can be widely used in food, beverage, medicine, cosmetics, electronic products and other industries, providing high-quality identification services for products in different fields.

PRINTING EFFECT



Cost-effective, high-quality printing

- ◆ Reduce pre printed inventory and waste.
- ◆ Plant oil-based environmentally friendly ink.
- ◆ Advanced technology, flexible printing resolution, and optimal print quality with minimal ink usage.

Code accuracy and consistency

- ◆ Smart integration with coding automation software for accuracy.
- ◆ Bar code scanner and vision control integration to confirm there adaptability of every printed code.



Big on Connectivity

- ◆ The CH700UV is Industry 4.0 ready and designed for seamless integration.
- ◆ A broad range of connectivity options for integration to factory equipment, using PLC standard interfaces including USB, Ethernet, RS232, Wifi.
- ◆ Simple Text transfer solutions for integration with a variety of host packaging and processing machinery.

Operational support

- ◆ No matter where you are, you can receive excellent after-sales service. We provide high-quality assistance manuals and instructional videos, as well as remote guidance from technical experts. 24X7 online service ensures that we can be with you when you need us the most.



TECHNICAL SPECIFICATION

Model	CH700UV
Max Printing Height	Single Head 71.8mm Max 287.2mm(4 heads)
Max Resolution	360DPI
Printing Distance	1-10mm
Printing Speed	Max 90m/min
Ink Type	UV ink, Oil ink
Ink Supply Method	Negative Pressure & Siphon(Optional)
Printing Direction	Vertical & Horizontal (Optional)
External Interface	USB, Ethernet, RS232, Wifi
Power Supply	100-240V, 50/60Hz
Package Size	125*110*145cm
Gross weight	210KG
Printing Lines	Unlimited number of lines (maximum nozzle height range, arbitrary layout)
Printing Contents	Variable and fixed text, pictures, PDF, Bar code, QR code, database, etc.
Printing Fonts	Windows operating system fonts
Transmission Interface	Gigabit network
Printing Method	Single or continuous printing
Ink Color	Black, white, red, blue, invisible ink, etc.
Nozzle Cleaning	One-button automatic cleaning

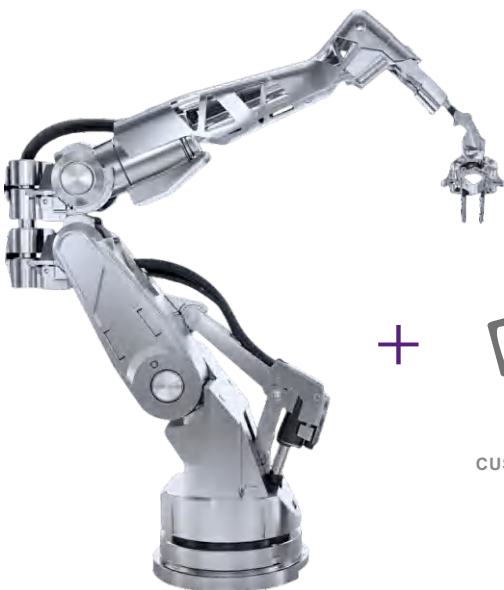

+



CUSTOMIZED SERVICES



DEVELOP SOFTWARE

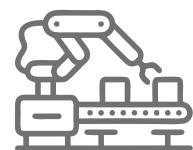

SUPPORTING AUTOMATED
PRODUCTION LINE



Contact Us

Web: www.cycjet.com

TEL: +86-21-59970419

FAX: +86-21-59971610

Email: service@cycjet.com

ADD: 1/F, BLDG. 4, NO. 333 HUAGAO RD., HUATING
IND. ZONE, SHANGHAI(201816) P.R.C

