

SMART THINKING  
SMART PRINTING

# AUTOMATIC DROP ON DEMAND INKJET PRINTING SYSTEM

## BROCHURE





# Clear, beautiful, stable printing

## 1 | PRODUCT DESCRIPTION

CYCJET D16L Large Character Inkjet Printer are widely used in building materials, chemical industry, pipes, packaging and other industries. It can print text, production date, batch number, etc. on the product surface. The machine uses a touch screen design with rich interface, simple operation and easy printing. Its nozzle is not easily clogged and is easy to maintain. In addition, it has strong heat resistance, anti-interference and is very practical. This machine can print larger font heights, which is helpful to meet customer needs for large character printing.

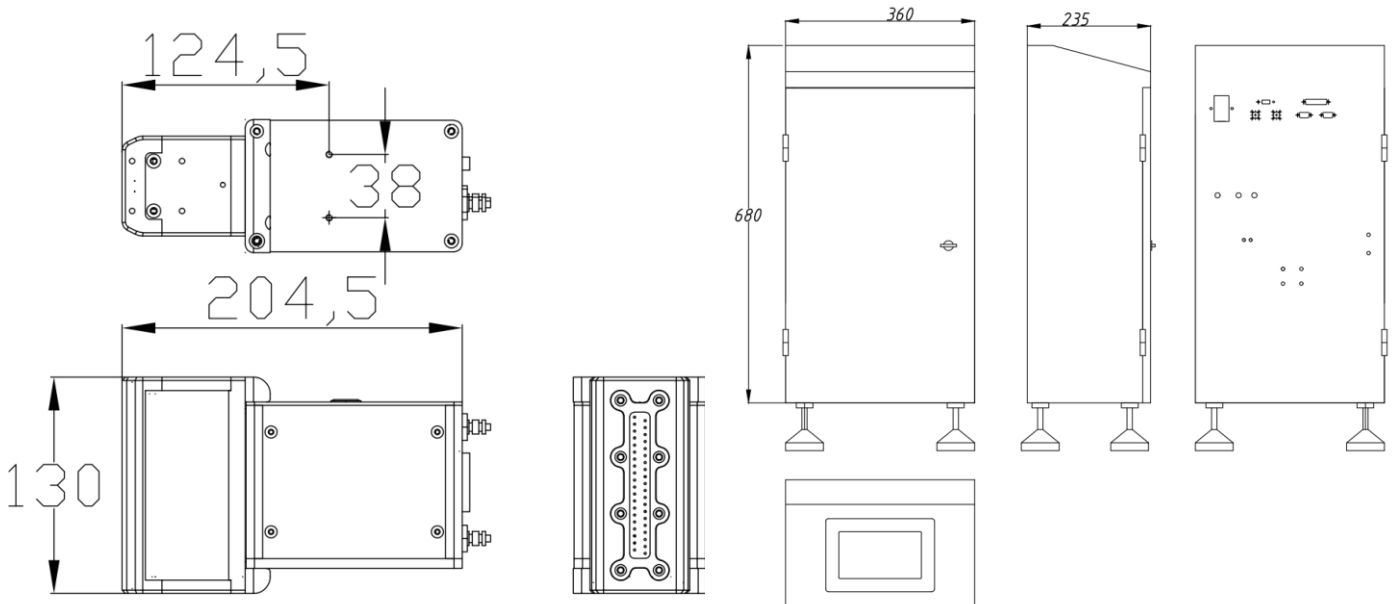

# DOD Technical Features

- **Usage environment:**

It can meet the needs of industrial inkjet printing and is suitable for harsh working environments, such as dust environment, humid environment, and vibration environment.

- **Wide application:**

The ink dries quickly and is suitable for industrial printing needs, such as carbon steel, cement products, etc. This machine can also print on cartons.

- **High stability:**

The machine has a simple structure, no need to consider the ink circuit system, easy to install, easy to operate, and has a low failure rate.

- **Low maintenance and operating costs:**

The ink circuit structure is simple and there is no complicated ink supply system. Only ink is required and running costs are low.

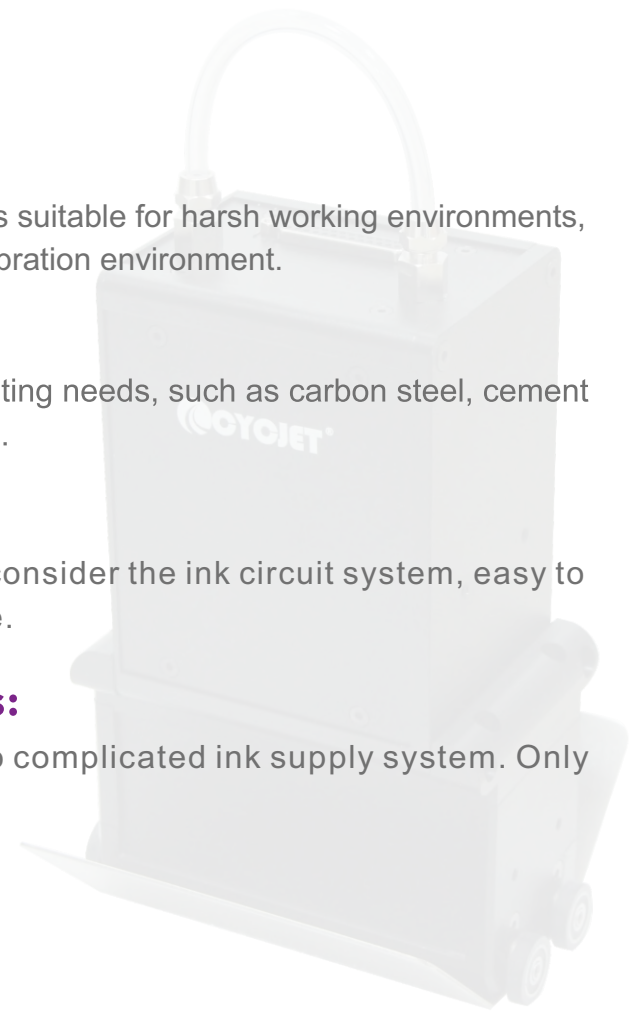

## APPLICATIONS

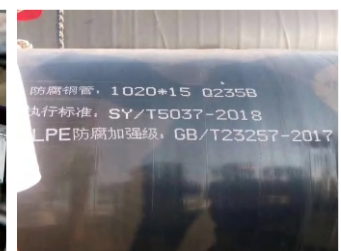
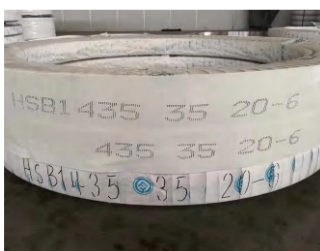
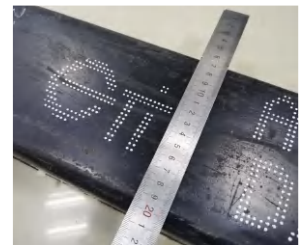

# TECHNICAL SPECIFICATION

Item	Model	Smart Online Inkjet Printer
		D16L
Print Height		25-50mm(16 dots)
Gross weight		38kg
Package Size		62×43×88cm
Display		7 inch touch screen
Print Rows		1-2 rows. Overall layout height not to exceed 50mm
Type		DOD Inkjet Printer
Basic Configuration		Printing max two lines or five lines of numbers, or English, all the national standard database of Chinese characters and English letters, self simple graphics, the machine without external gas source, free warranty for one year. (Optional)
Software Function		Real-time clock date, product counting, frequency
Operation Function		English operation system, delay in printing, the font width, font height, orientation, self-cleaning. sensor settings.
Print Speed		0.2-60m/min
Battery Capacity		Plugged in
Powder		AC220V±10%, 50-60HZ, 5 W
Print Spacing		8-10mm
Print Content		Real date, Real time, photo, letter, shift group, serial number, batch number, barcode and QR code, etc.
Printing Direction		Upward printing, downward printing, side printing (360°direction printing, optional)
Typeface		Chinese, English, Arabic, Russian, Spanish, Faris, Italian etc... (Customized available)
Memory Function		3GB storage space, each file can store up to 400 characters
Ink Type		Water-based ink, ketone-based ink, alcohol-based ink, other special-based inkcan be customized as required
Ink Color		black, red, yellow, blue, white, etc. (optional)
Body Material		Industrial grade stainless steel body
Humidity Range		10-90% Non-condensing
Temperature Range		5-40°C
Others		No need to connect external compressed air, and no need thinner (i.e. solvent)



## Contact Us

---

Web: [www.cycjet.com](http://www.cycjet.com)

TEL: +86-21-59970419

FAX: +86-21-59971610

Email: [service@cycjet.com](mailto:service@cycjet.com)

ADD: 1/F, BLDG. 4, NO. 333 HUAGAO RD., HUATING  
IND. ZONE, SHANGHAI(201816) P.R.C

