



SOLUTIONS



SERVICE



TECHNOLOGY

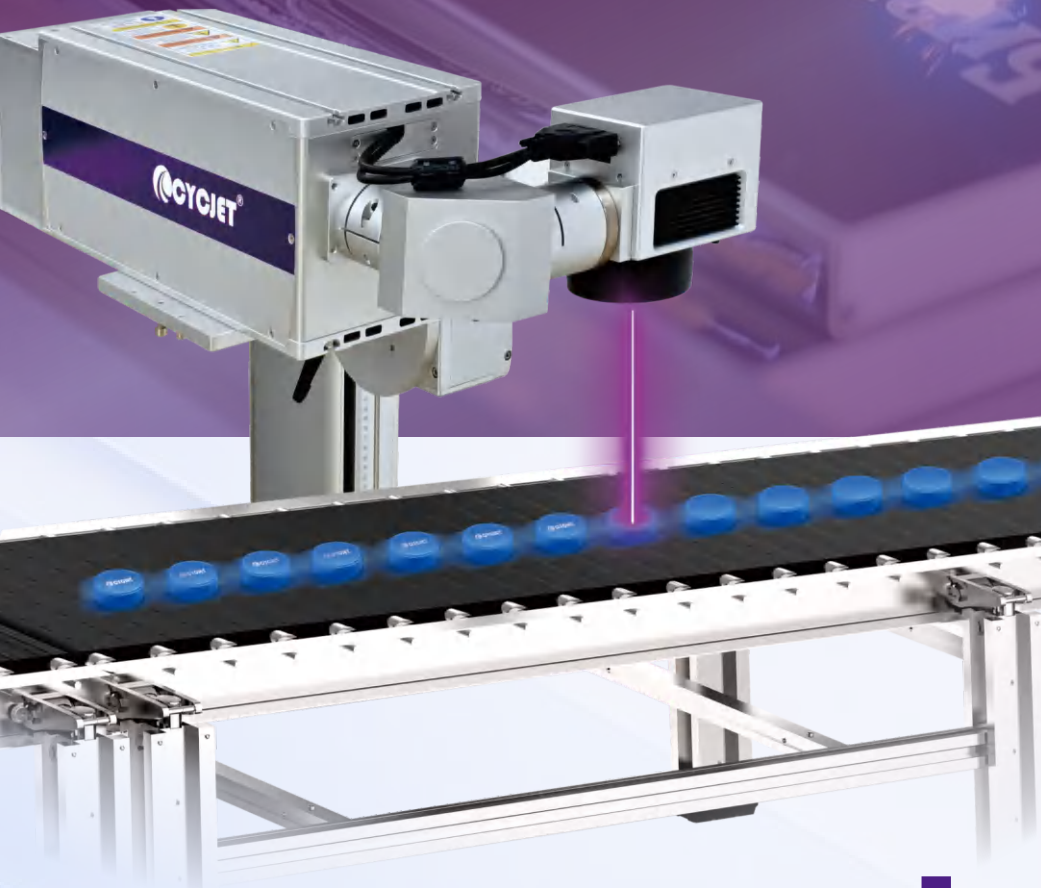

LU25F

BROCHURE



LU25F UV LASER

Mark Your Products



1 | PRODUCT DESCRIPTION

LU25F UV laser fly marking machine belongs to the fly laser marking series products independently developed by CYCJET, which is mainly used in the high-end market of ultra-fine processing. Marking of packaging bottles of cosmetics, medicines, foods and other polymer materials, flexible PCB boards, dicing, micro-hole and blind hole processing of silicon wafers, LCD liquid crystal glass, metal surface coating marking, plastic buttons, electronic components, communication equipment, building materials, etc.

2 | ADVANTAGES

- Codes are bright white on dark plastics and deep black on white plastics
- The powerful laser tube is ideal for high-speed and on-the-fly applications
- The compact all-in-one controller and laser unit makes production line integration easy
- The adjustable LU25F scan-head can be mounted in horizontal or vertical orientation
- Vision system integration enables automated code inspection
- Easy audit trail implementation helps to achieve a compliant solution

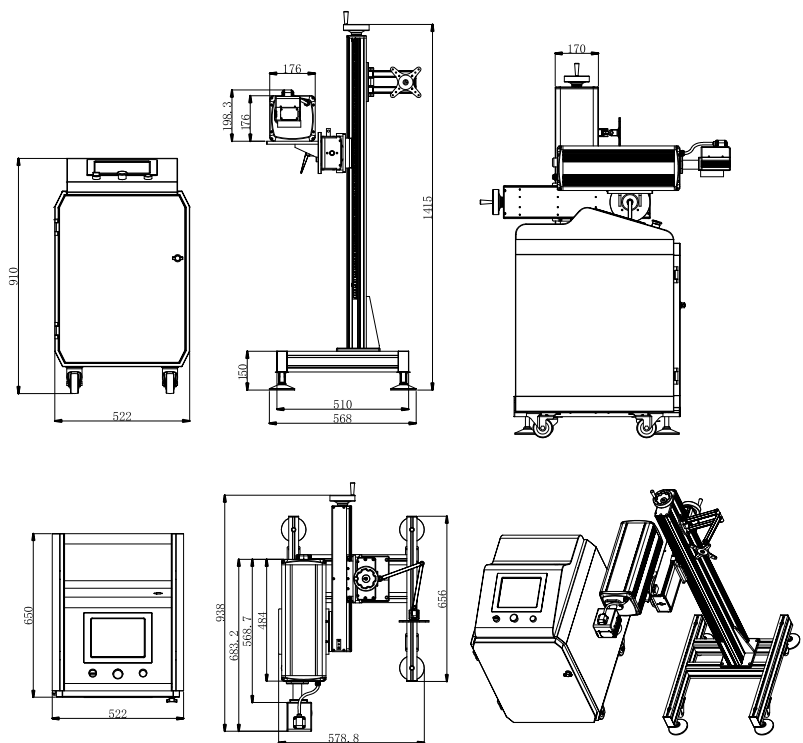

MARKING EFFECT

You can achieve higher throughput with **high quality** and **complex codes**,
30%
faster than competitor lasers



You can be **100%**
compliant with industry standards with permanent and consistent printing in conditions up to 45 °C

You can **improve** your line reliability and **coder lifetime** by **30%**, with **60,000** hours MTBF (meantime between failure)



You can achieve **uptime** of **99.9%** in tough conditions with minimal maintenance, no plant air and IP55* as standard

TECHNICAL SPECIFICATION

MODEL		LU25F
PERFORMANCE	Frame Material	ALUM
	Laser Device	Cable & pipe UV Laser
	Power	25W
	Laser Wavelength	355nm
	Galvanometer deflection	High Precision dual dimensional scanning system
	Marking speed	≤18000mm/s
	Master Control	Highly integrated board with 10 inch Color Touch screen
	Operating System	LINUX based with High Speed Pipe Marking Software
	Cooling	High Capacity Water Cooling System
Marking Specifications	Focus Distance	Focus 200mm
	Marking line type	Dot matrix, bold, vector all in one(both dot matrix and vector)
	Minimum line width	0.01mm
	Repeatability accurate positioning	0.003mm
	Marking Area	Standard 110mm×110mm(Customized available)
	Marking height	Standard Character height 110mm
	Marking Length	Unlimited
	Positioning mode	Red light positioning and focusing
	Number of characters	Any line(multi-line) within marking range
	Line Speed	Standard 0~120m/min (depends on material &text)
Support type	Typeface	Chinese, English, Arabic, Russian, Spanish, Faris, Italian etc... (Customized available)
	Marking	Number, logo, image, letter, serials number, system date & time,etc...
	File format	CNF, PLT, JPG, CRD, BMP
	Bar code	CODE39、CODE128、CODE126、QR、Z-Code
Others	Power Supply	100-220V/50-60HZ
	Power Consumption	600W
	Gross weight	About 94kg
	Package Size	93*62*111cm
Environmental Requirement		0°C —45°C; humidity≤95%; non-condensing; no shaking

The Quality Standard of CYCJET UV Laser Marking Machine

GB 7247-87	Radiation safety of laser products, requirements for equipment classification and user's Guide
GB10320-88	Electrical safety of laser equipment and facilities
ISO 9000-3	International software standards
GB/T12123-89	Sales packaging process
IEC 536	Classification of electrical and electronic equipment for protection against electric shock



Contact Us

Web: www.cycjet.com

TEL: +86-21-59970419

FAX: +86-21-59971610

Email: service@cycjet.com

ADD: 1/F, BLDG. 4, NO. 333 HUAGAO RD., HUATING
IND. ZONE, SHANGHAI(201816) P.R.C

