



SOLUTIONS



SERVICE



TECHNOLOGY



LC30F

BROCHURE



LC30F CO₂ laser marker

marking with the energy of light

CYCJET has developed globally leading laser technology and designed the LC series flying laser printer, which is the latest application based on good market experience in cosmetics, pharmaceuticals, beverages and beverage packaging, food packaging, cables and plastic pipes. This printer is designed to be compact and highly integrated, suitable for fast and long-term printing on plastic pipes, and can meet 24-hour continuous operation. Intelligent and simple operation, adaptable to different line speeds and materials



Flexibility, Integration and Performance

For line integration

- ✔ More than 50 standard beam delivery options, a 360° rotatable scanhead, and customisation options for specific needs.
- ✔ Seamless integration into ERP, WMS, and MES systems.
- ✔ Web-based user interface and easy operation via an intuitive HMI

For tough environments

- ✔ Dusty, wet, sticky- no problem with IP54/IP65 printheads and IP55 controller for protection.
- ✔ Performs at 45°C ambient temperature.

For performance

- ✔ Good spot quality, high laser power, maintenance free, Clear markings, not easily worn, no consumables, low cost
- ✔ The lifespan of the laser source is long, with an average time between failures (MTBF) of 40000 hours of use
- ✔ Supports multiple file formats such as PLT, AI, DXF, BMP, JPG, etc

Permanent traceability coding in excellent quality



PET - ideal for the beverage industry designed for high production rates and with optional IP55 or IP64 certification.



Glass- the **LC30F** codes at speed in excellent quality even on tough substrates.



Films (PP, aluminium)-ideal for pots and stickpacks: large marking fields, pin-sharp small characters, gentle coding that helps keep protective barriers intact.



Plastics- smart 2D coding that's ready for GS1 Sunrise: variable data helps unlock the full potential and supports authentication and anti-counterfeiting.

TECHNICAL SPECIFICATION

Model	LC30F
Frame Material	ALUM.
Laser Type	Specialized High-speed CO2 Laser
Power	≥30W
Laser Wavelength	930nm/1064nm/1020nm
Galvanometer Deflection	High precision dual dimensional scanning system
Master Control	Highly integrated board with 10 inch color touch screen
Operating System	LINUX based with high speed marking software
Cooling System	Air Cooling System
Focus Distance	135mm (Customized available)
Minimum Line Width	0.012mm
Repeatability Accurate Positioning	0.003mm
Marking Line Type	Dot matrix, bold, vector all in one (both dot matrix and vector)
Marking Area	Standard 110x110mm (Customized available)
Marking Height	Standard character height 110mm
Marking Length	Unlimited
Typeface	Chinese, English, Arabic, Russian, Spanish, Faris, Italian etc... (Customized available)
Marking Content	Number, logo, image, letter, serial number, system date & time, etc.
File Format	CNF, PLT, JPG, CRD, BMP
Barcode Type	CODE39、CODE128、CODE126、QR、Z-Code
Power Supply	100-220V/50-60HZ
Power Consumption	600W
Gross weight	123kg
Package Size	135X75X47cm
Environmental Requirement	External Temperature 0°C-45°C; humidity≤95%; non-condensing; no shaking

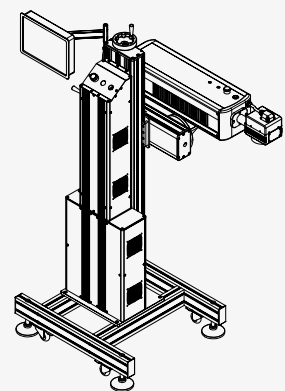
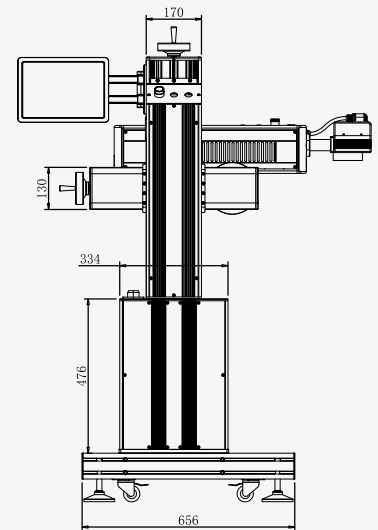
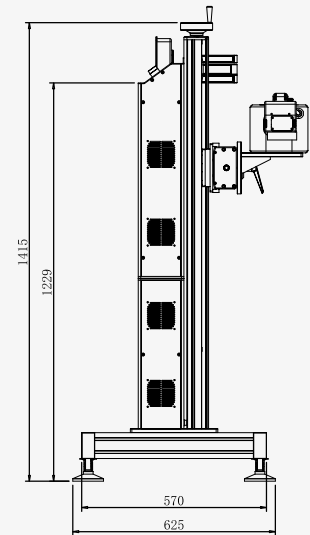

The Quality Standard of CYCJET Fly Laser marker

GB 7247-87	Radiation safety of laser products, requirements for equipment classification and user's Guide
GB10320-88	Electrical safety of laser equipment and facilities
ISO 9000-3	International software standards
GB/T12123-89	Sales packaging process
IEC 536	Classification of electrical and electronic equipment for protection against electric shock



Contact Us

Web: www.cycjet.com

TEL: +86-21-59970419

FAX: +86-21-59971610

Email: service@cycjet.com

ADD: 1/F, BLDG. 4, NO. 333 HUAGAO RD., HUATING
IND. ZONE, SHANGHAI(201816) P.R.C

